

 Electronics Design Laboratory	Electronics Design Laboratory 124 Burr Hall Kansas State University Manhattan, KS 66806-0400 785-532-7826			
	Project: Differentially Isolated Adapter Card			
Project Code: HEP064	Page Title: 4-Channel		Page Date: Thursday, April 01, 2004	CAGE Code: 4B817
Approvals:	Rev. 1.0	Design Date: Thursday, April 01, 2004	Sheet 1 of 5	

Note: Pin 1 and Pin 23 to be used for shield.

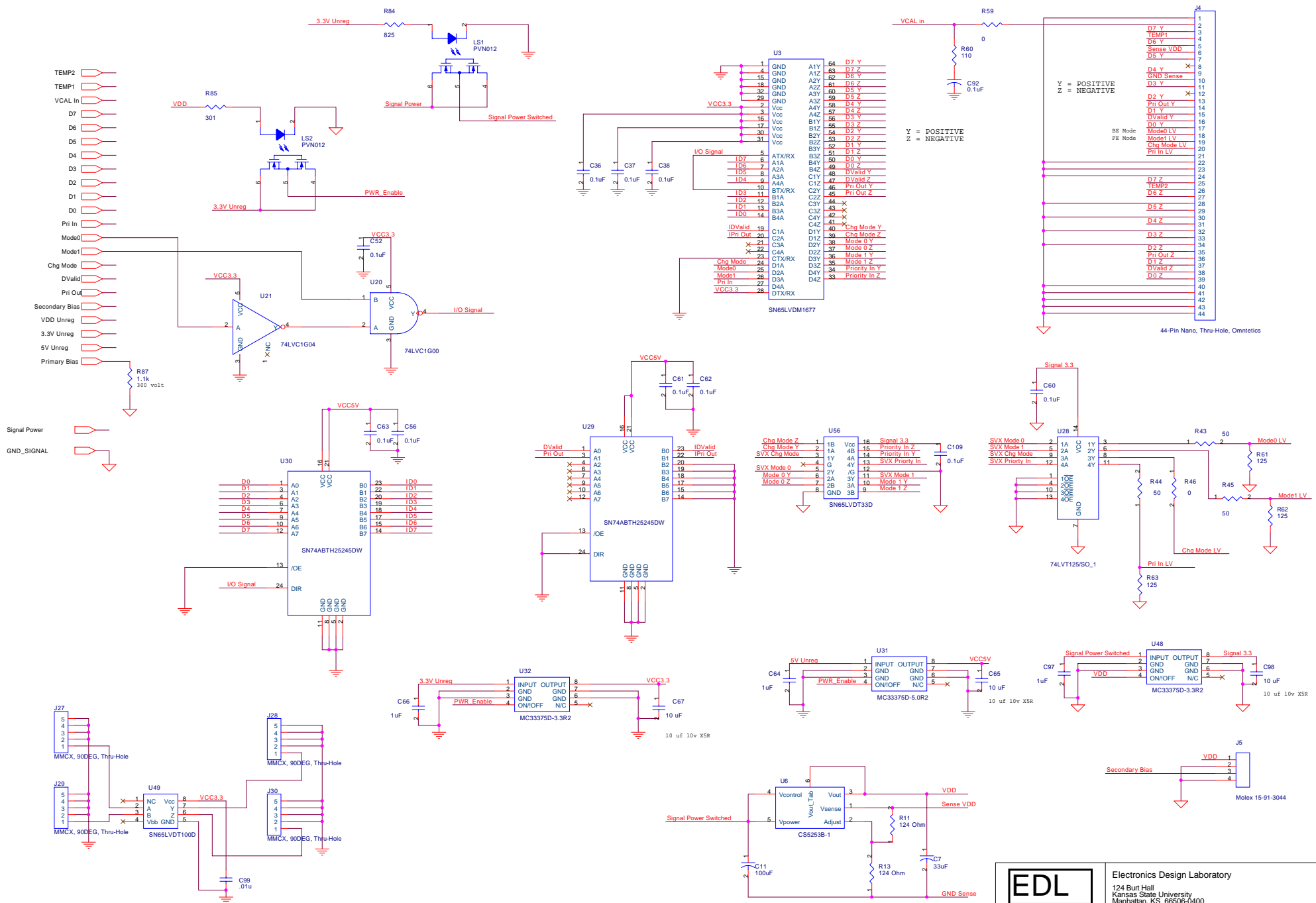

EDL Electronics Design Laboratory	Electronics Design Laboratory 124 Burr Hall Kansas State University Manhattan, KS 66806-0400 785-532-7826		
	Project: Differentially Isolated Adapter Card		
Project Code: HEP064	Page Title: Single Channel		
Approvals:	Rev. 1.0	Page Date: Wednesday, March 31, 2004	CAGE Code: 4B817
Size: C	Design Date: Wednesday, March 31, 2004	Sheet 2 of 5	

Note: Pin 1 and Pin 23 to be used for shield.

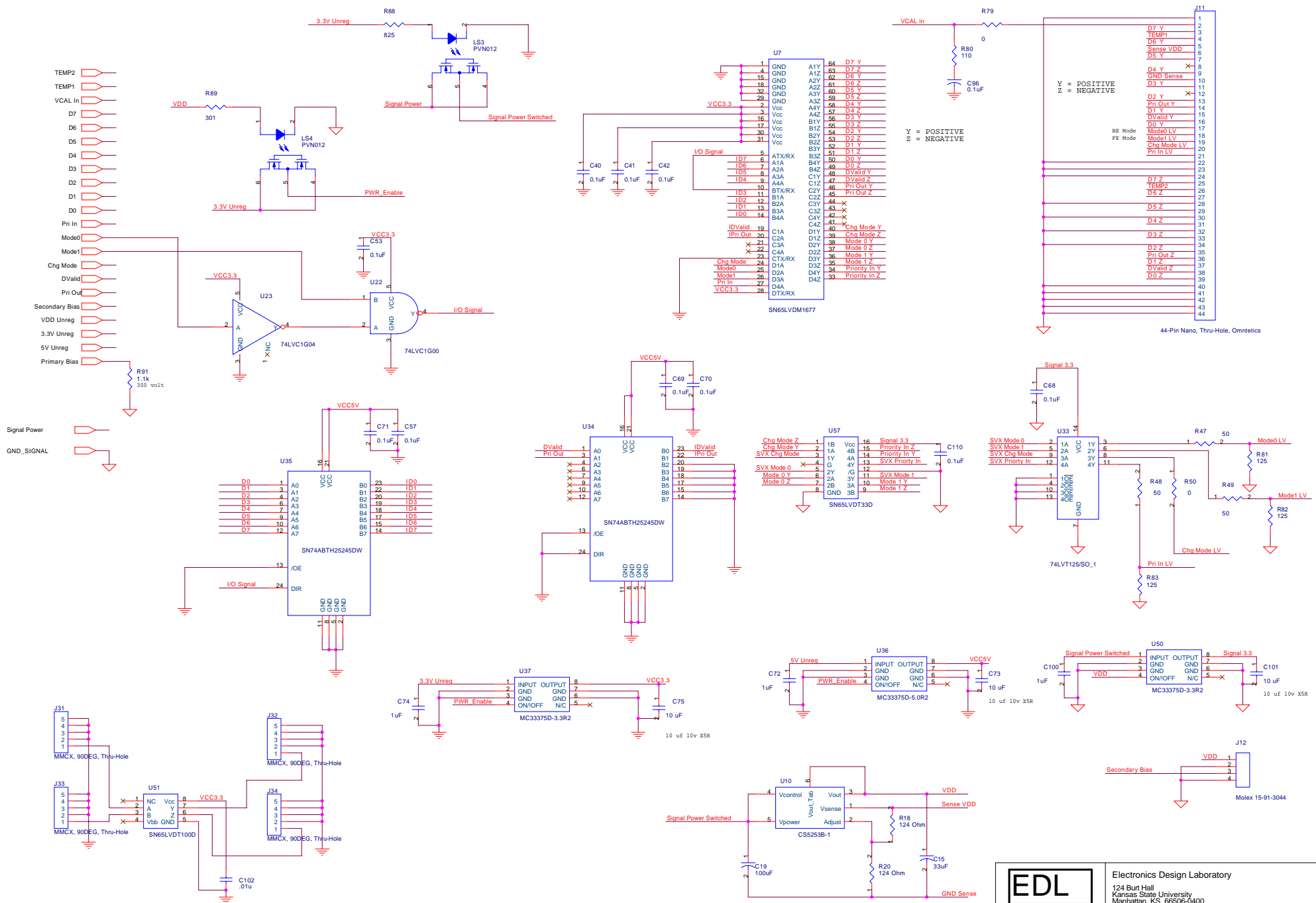

		Electronics Design Laboratory 124 Burr Hall Kansas State University Manhattan, KS 66806-0400 785-532-7826	
		Project: Differentially Isolated Adapter Card	
Project Code: HEP064		Page Title: Single Channel	
Approvals:		Rev. 1.0 Size: C	Page Date: Wednesday, March 31, 2004 Design Date: Wednesday, March 31, 2004
		CAGE Code: 4B817	Sheet 3 of 5

Note: Pin 1 and Pin 23 to be used for shield.

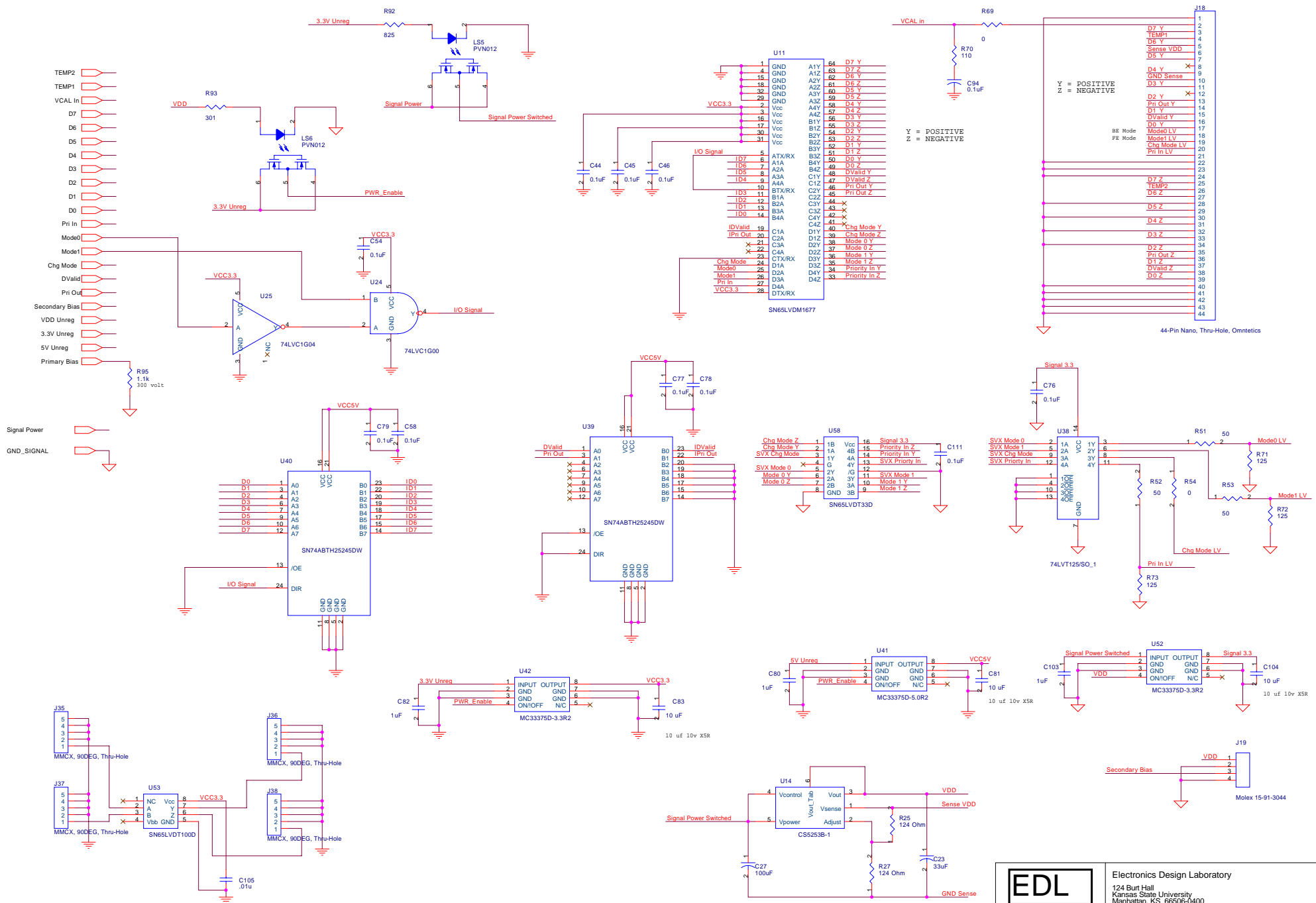

		Electronics Design Laboratory 124 Burr Hall Kansas State University Manhattan, KS 66806-0400 785-532-7826	
		Project: Differentially Isolated Adapter Card	
Project Code: HEP064		Page Title: Single Channel	
Approvals:		Rev: 1.0 Size: C	Page Date: Wednesday, March 31, 2004 Design Date: Wednesday, March 31, 2004
		CAGE Code: 4B817	Sheet 4 of 5

